

100/107 Series

Plow Harness Lift Group For Motor Graders

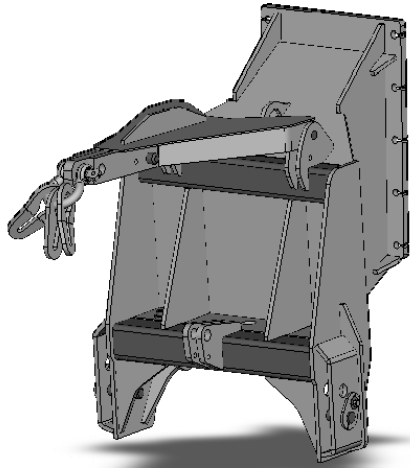

100 Series Standard Lift Group

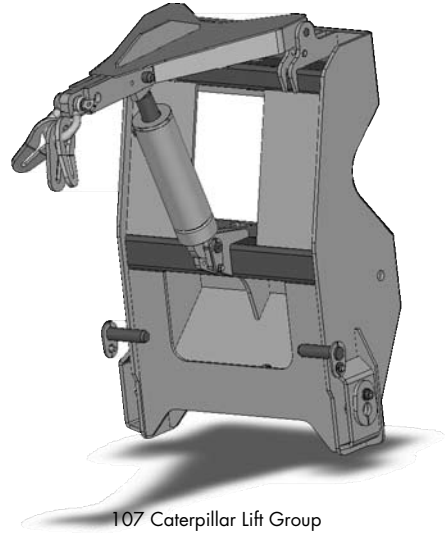

107 Caterpillar Lift Group

100 Series Lift Group

- Boxed section frame design bolts to factory mounting holes and allows clearance of front tires in all positions
- Provides up to 17" of lift
- Lift cylinder features a 4" bore, 2" shaft and 13.75" stroke
- Lift cylinder rated to 3000psi
- Parallel push pole pockets secure the plow using 1.25" diameter, 5.75" long cold rolled pins
- 1" clevis secures 3 1/2" plate slip links for grade 70 plow chain
- Lift Group can be custom engineered to work with existing attachments
- Weight: 800lbs

107 Series Lift Group

- Designed specifically for Caterpillar motor graders
- Boxed section frame design bolts to factory mounting holes and allows clearance of front tires in all positions
- Provides up to 17" of lift
- Lift cylinder features a 4" bore, 2" shaft and 9.25" stroke
- Lift cylinder rated to 3000psi
- Parallel push pole pockets secure the plow using 1.25" diameter, 5.75" long cold rolled pins
- 1" clevis secures 3 1/2" plate slip links for grade 70 plow chain
- Lift Group can be custom engineered to work with existing attachments
- Weight: 800lbs

Craig Manufacturing Ltd. warrants to the original purchaser all products manufactured by CRAIG to be free from defects in material and workmanship for a period of (12) months starting from the date of delivery from factory unless otherwise specified.

