

## 302-12RM Series

# 12' High Lift Wing Assembly For Motor Graders

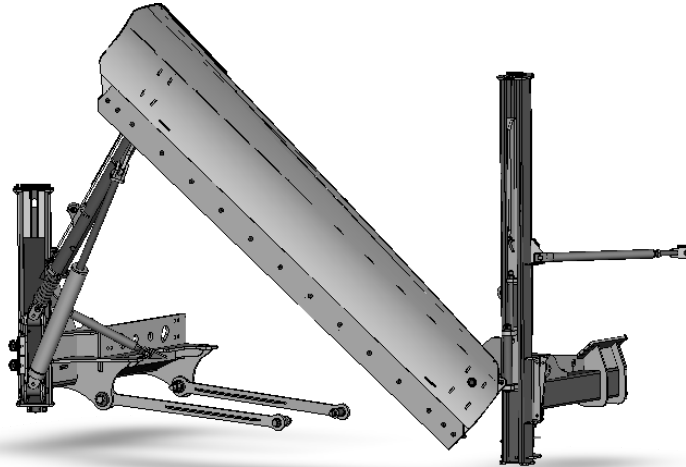

### Moldboard

- Gives you the ability to wing with the same attack angle & same reach from 0" to 60" bench height
- Moldboard has an overall length of 12'6" with an intake height of 27" and a discharge height of 43"
- Moldboard is 3/16" thick
- 5/8" thick x 8" cutting edge secured with 5/8" bolts (12" inches on center with extra at edges)
- 12' Reversible high abrasive steel cutting edge
- Front of snow wing is fastened to front post with a 1-1/2" diameter grade 2 shear bolt

### Front Post

- Safety chain securely fastens the snow wing to the front post
- Front post works in conjunction with the snow wing and rear lift group
- Front post allows 60" of shelving / benching height
- Front post features 12" of free float
- Front post slides are to be actuated with a 2-1/2" bore, 1-1/2" shaft cylinder

### Rear Lift Group and Push Pole

- Rear post mounting bracket uses a boxed section design securely mounted to the rear frame of the grader behind the right rear wheel
- Rear lift group is fully hydraulic and consists of an inner and outer push pole complete using a 4" bore, 2" shaft lift cylinder and a 3" bore, 2" push pole extension cylinder
- Rear slide is equipped with a 2.5" bore, 1.5" shaft cylinder which provides 30" of lift
- Rear lift group features a three (3) point hookup design, two (2) on the grader and one (1) on the wing
- Moldboard end of push pole extends and retract 21-1/2" hydraulically
- Bracket end of push pole features a shock absorbing spring
- Push pole lugs that attach to cylinders have self aligning bushings press fit into the cylinder lugs
- Weight: 12' 4,090lbs (13' 4,163lbs)

Craig Manufacturing Ltd. warrants to the original purchaser all products manufactured by CRAIG to be free from defects in material and workmanship for a period of (12) months starting from the date of delivery from factory unless otherwise specified.

**CRAIG**  
QUALITY WE STAND BEHIND  
Attachments • Built Right • Fit Right



## 300-12RM, 301-12RM & 302-12RM Series Wing Assembly Options and Hydraulic Requirements

---

### Wing Assembly Options

Extra-long 13'6" Moldboard (13" cutting edge)

- Reversible Carbide Cutting Edge
- Trip Edge
- Hydraulic Trip Swivel
- Hydraulic Quick Disconnects
- Quick Disconnect Push Pole Bracket (includes hydraulic quick disconnects)
- Heavy-Duty Long Reach Push Pole
- Curb Shoes
- Wing Moldboard Wear Shoes
- Rear-Post can be custom engineered to work with rear mounted attachments (ripper, rock rake, etc)

### 300-12RM Recommended Hydraulic Cylinder Flow Rates

- Rear Extend (work port relief @ 1100psi /anti-cavitation recommended) 8-15gpm (30-57L/min)
- Front post minimum of 5gpm (19L/min)
- Hydraulic pitch control (if equipped) minimum of 5gpm (19L/min)
- Rear lift (float required) 20gpm (76L/min)

### 301-12RM Recommended Hydraulic Cylinder Flow Rates

- Rear Extend (work port relief @ 1100psi /anti-cavitation recommended) 8-15gpm (30-57L/min)
- Front post minimum of 5gpm (19L/min)
- Rear lift (float required) 20gpm (76L/min)
- Hydraulic trip swivel (if equipped) minimum of 5gpm (19L/min)

### 302-12RM Recommended Hydraulic Cylinder Flow Rates

- Rear Extend (work port relief @ 1100psi /anti-cavitation recommended) 8-15gpm (30-57L/min)
- Front post minimum of 5gpm (19L/min)
- Rear lift (float required) 20gpm (76L/min)
- Rear post minimum of 5gpm (19L/min)
- Hydraulic trip swivel (if equipped) minimum of 5gpm (19L/min)

Craig Manufacturing Ltd. warrants to the original purchaser all products manufactured by CRAIG to be free from defects in material and workmanship for a period of (12) months starting from the date of delivery from factory unless otherwise specified.

