

## 0600 Series

# 12' Hydraulic Reversible Plow For Wheel Loaders

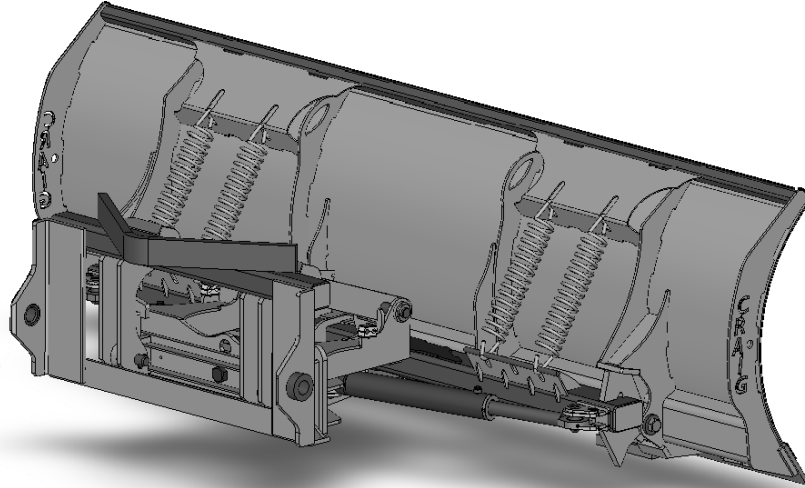

### Overview

- 144" wide, 3/16" thick moldboard
- Angles 30° left and right
- 12' straight cleared path
- 10'4" cleared path at 30° angle
- 52" tall moldboard
- 4 heavy duty springs allow moldboard to trip
- Moldboard trips up to 66°
- Moldboard is constructed with a continuous curve
- Two lifting hooks for handling Installed on the back of the moldboard

### Wear Components

- High abrasive steel reversible cutting edge is 8" x 144" x 5/8"
- Cutting edge secures to moldboard using 5/8" carriage bolts
- Cutting edge bolt holes are spaced 8" on center
- 1.5" replaceable wear shoes are secured and adjusted using two 5/8" grade 8 bolts each for 6" of height adjustment

### Pivot Beam / Push Frame

- Push frame connects to moldboard via a 6" X 4" X 1/2" square tube pivot beam
- Pivot beam connects to moldboard with four 1.25" grade 8 bolts
- Frame and beam pivot on a 2" cold rolled pin
- Push frame is constructed from 1/2" plate and 4" x 4" x 1/2" square tubing
- Two 3" bore, 1.5" shaft, 19.25" stroke cylinders actuate the pivot beam
- Push frame is available with 1/2" lift chains or 1" push arms for downpressure float

### Options

- High curl moldboard
- Widths from 10' to 14'
- Reversible carbide edge
- Manual or hydraulic end gates
- Rubber deflector and visibility flags

Craig Manufacturing Ltd. warrants to the original purchaser all products manufactured by CRAIG to be free from defects in material and workmanship for a period of (12) months starting from the date of delivery from factory unless otherwise specified.

**CRAIG**  
QUALITY WE STAND BEHIND  
Attachments • Built Right • Fit Right